

E8000 tech specs

Frame	T6 heat-treated, 7005 aluminium designed for Shimano STePS e8000 motor.
Fork	Chromoly steel with tapered steerer tube.
Kickstand	Aluminium with replaceable feet.
Headset	1½" FSA Orbit XII, 1½" tapered 1½".
Steerer arm	Chromoly steel with machined fittings and rubber covered balljoint.
Dropouts	Aluminium, machined and replaceable.
Shimano	STePS system
Motor	Bottom bracket mounted for low centre of gravity and light; 2.8kg. 250W/70Nm Torque max output.
Battery:	High capacity, 504Wh and low charging time of 4 hours; 2.62kg.
Crankset:	Hollowtech II style, 38 tooth chaining.
Shifter:	XT di2
Rear Derailleur:	XT di2
Front wheel:	Novatec hub, sealed bearings, 10mm axle, laced to Alex 36H Supra rim.
Rear wheel:	Novatec hub laced to Alex 36H Supra rim.
Cassette:	Shimano XT 11-42
Tyres:	Schwalbe Kojak 20" x 1.35', 26" x 1.35', extra set, Schwalbe Marathon Supreme 20" x 1.6', 26" x 1.6'
Fenders:	Plastic, black.
Brakes:	Shimano Zee 4-pot disc brakes, 180mm Shimano rotors
Handlebar:	Thomson Trail, 750mm, 31.6 mm alloy riser bar, black.
Stem:	Thomson X4 50mm, black.
Stemlifter:	EasyUp 100mm of adjustment, black.
Grips:	Velo Ergo lock-on.
Bell:	Brass Japanese Wind Bell, black.
Saddle:	Original Bullitt Racing Seat from Velo, black.
Seatpost:	31.6 mm alloy, 410mm, black.
Seat clamp:	Thomson, fixed.
Front lights:	Busch Müller Lumotec IQ2 Eyc powered from main Shimano battery.
Rear lights:	Busch Müller Secula powered from main Shimano battery.
Chain:	KMC
Lock:	ABUS Amparo, ABUS Key Alike© integration with STePS battery.

Contact information



HQ - Larry vs Harry, Esromgade 15, opg. 2 (rampen), DK-2200 Copenhagen
Bullitt Store - Frederiksborggade 43, DK-1361 Copenhagen Denmark

www.larryvsharry.com

e BULLITT®



SHIMANO STOPS

E8000



Welcome to Larry vs Harry

Larry vs Harry is a company, dedicated to bringing you the finest and most most versatile bicycles. The Larry vs Harry Bullitt is sold throughout the world. Just about anywhere you go, you'll find Bullitts. These graceful beasts can be seen transporting goods and people, they can be seen riding leisurely or going fast-faster-fastest.... They are a bicycle for everyone and anyone.

We are a small company with the support of dozens of dedicated and enthusiastic dealers, that will make your ride safe and fun. Authorized Bullitt dealers are the only place where you can buy the Bullitt product of your choice or direct from us here in Denmark. We are dedicated to the independent bicycle dealers in your area because they are the most professional and best-qualified source to assure your bike's mechanical integrity, guarantee proper fit, give you proper advice on where and when to ride, consult with you about safety, properly assemble and install accessories, and to communicate anything and everything else you need to know about the glorious pursuit of cycling!

Our employees and dealers are justifiably proud of our international reputation as an innovative and quality driven company, where service and the enjoyment of the rider is the highest priority. We have spent unfathomable amounts of time developing the Bullitt, learning our craft and winning multiple awards for excellence along the way. Our models are designed for the broadest user base, using components and parts that deliver performance, durability and value and we focus on products that work well with the Bullitt.

The Bullitt is a bicycle designed for all to use, professionals and families alike, in all weathers and all environments. Our contributions to cycling encompass many facets of the lifestyle, from transportation to recreation to competition. At Larry vs Harry, we believe that the Bullitt is more than just a machine. We believe that it is an integral component of society, a trusted companion, and a way to explore the world. Thank you for buying a Bullitt, now go out and enjoy riding it! Larry vs Harry

Thank you for buying a Bullitt, now go out and enjoy riding it!

Larry vs Harryv



Attention

Check the tyres are properly pumped, you can find the maximum pressure on the tyre sidewall, but we recommend 80psi/5.5bar in the rear and 60psi/4bar in the front tyre. Always check local traffic laws to ensure your eBullitt is compliant with local traffic laws and has the correctly located reflectors and bell. When riding in dimly lit areas or at night, make sure your lights are functioning properly. The Shimano Steps System has rather ingeniously incorporated the lights into the main battery, so you never need worry about replacing batteries again. Familiarise yourself however, with the handlebar functions to correctly switch the lights on and o. Expected longevity of your eBullitt: With care and due attention you will be riding your eBullitt for many, many years.

We have tested the frames under duress and have spent years developing the Bullitt platform and are confident that it will hold up to sustained use, regardless of it's function. This said, parts are subject to wear and tear; tyres chains and brake pads need changing on average once a year and the bikes can be easily serviced by your local dealer or local bike shop. Only the chain should be lubricated with oil, never put oils/lubricants on the disc brakes, it will contaminate the pads and necessitate in replacements.

Wheels should be checked sporadically for loose spokes or the wheel is at risk of buckling. Refer to the Shimano Steps User Manual for specifics on the motor/drivetrain/battery. Please refer to our Terms and Conditions (http://shop.larryvsharry.com/terms_and_conditions) to see specifics on the frame and parts warranty. Additionally, common sense tells us nothing lasts forever and it goes with saying that bicycles suffer from metal fatigue. This applies to aluminium bike frames too and in adverse weather, this will exacerbate and speed up wear and tear. Salt on roads, wet weather and the stress and strain will all take their toll on your eBullitt, but frequent washing, care and maintenance will ensure a prolonged lifespan.

If your bicycle sustains an impact:

First, check yourself for injuries, and take care of them as best you can.

- Seek medical help if necessary.

Next, check your bike for damage. After any crash, take your bike to your dealer for a thorough check. Components, including frame and fork, wheels, handlebars, stems, cranksets, brakes, etc. which have sustained an impact must not be ridden until they have been disassembled and thoroughly inspected by a qualified mechanic. **WARNING:** A crash or other impact can put extraordinary stress on bicycle components, causing them to fatigue prematurely. Components suffering from stress fatigue can fail suddenly and catastrophically, causing loss of control, serious injury or death.



Parts overview

eBULLITT®

SHIMANO
STEPS
E8000

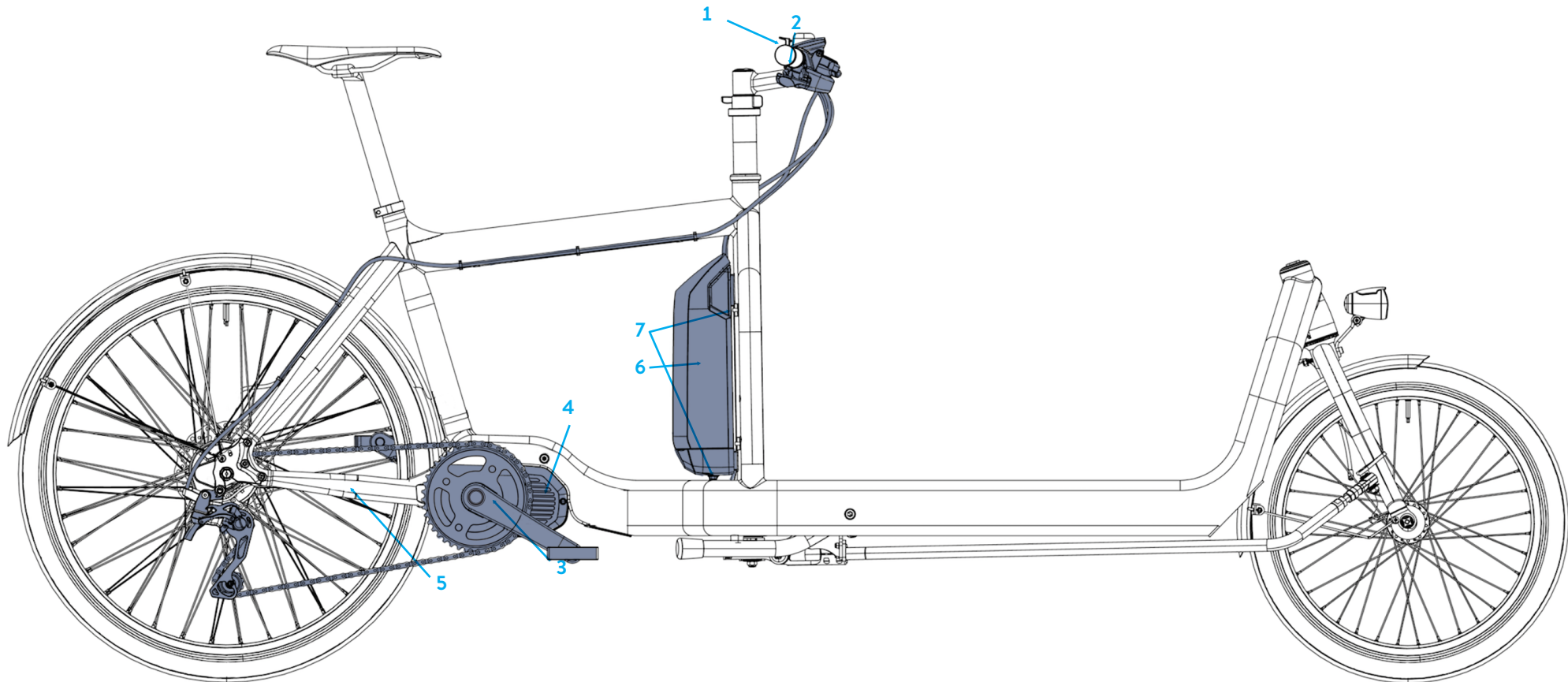

- | | |
|-------------------------------|-------------------|
| 1 Steps Computer Display | 5 Speed Sensor |
| 2 Mode/Gear Selection Buttons | 6 Battery |
| 3 Crankset | 7 Battery Mount |
| 4 Motor Unit | 8 Battery Charger |

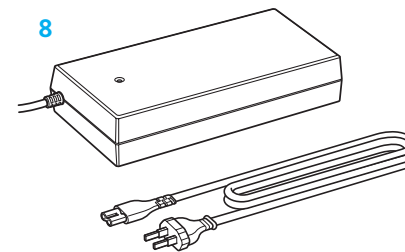

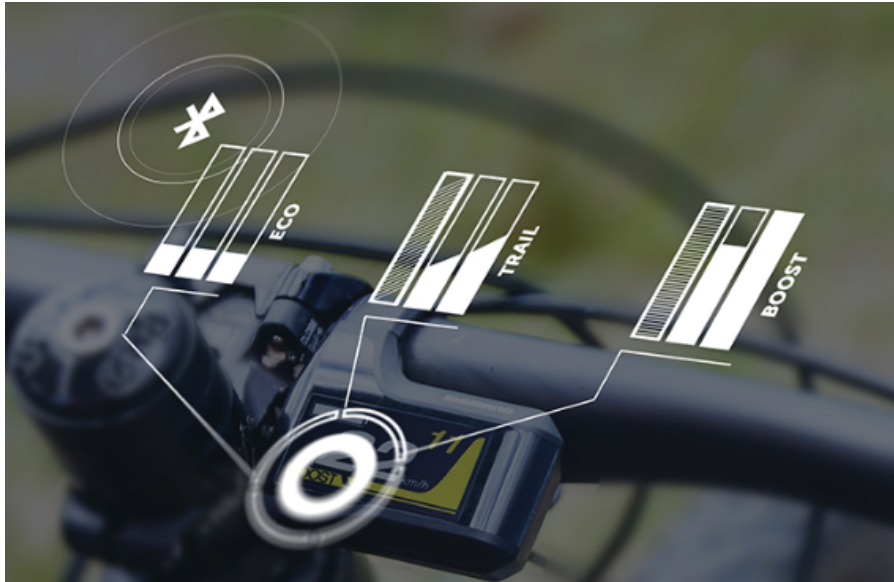

Quick start guide

Ensure the battery of your Steps e8000 Bullitt is fully engaged in the battery mount and hold down the power button to initialise the display on the handlebar. Now, let's take a look at the controls; the left hand shifter controls the display and assistance modes, Eco, Trail and Boost. The more assistance the motor gives, the easier pedalling becomes though obviously affects the longevity of the battery. The computer displays both speed and time, battery levels and chosen assistance mode and via Bluetooth firmware updates offers dynamic, explorer and custom modes to fine tune power delivery. The right hand gear shifter moves you through the 11 speed di2 gear range and is designed to feel tactile and replicate a traditional mechanical gear shifter. The selected gear is shown in the bar running along the bottom of the display. Familiarise yourself with the feeling of the Shimano Zee hydraulic brakes, they are powerful and the modulation may get a bit of getting used to.

Introduction

Thank you for buying the new Larry vs Harry eBullitt, based on the superb Shimano Steps e8000 system. This bike marks a new generation and evolution in bicycle technology which we are truly proud to bring onto the market, integrating all the electronic elements, including motor assistance, gear shifting and lights into one cohesive unit. We recommend that you read the Shimano Steps manual in its entirety, to fully understand all the features and attributes of the system. However, if you are in a hurry to start using your Steps e8000 Bullitt, here is a little run-down to get you rolling...

Assembly guide

Assembly time should be around 30 minutes and involves mounting the fork and front wheel, the rear derailleur and chain, rear mudguard and rear wheel and attaching the handlebar and stem. To mount the fork: Place the larger of the two headset bearings over the fork steerer and insert the fork into the headtube. Next, set the remaining cartridge bearing onto the protruding fork steerer and insert the retainer clip/preload spacer. Finally, screw the compression cap into the fork and tighten by hand until fully inserted. Then tighten with a 5mm allen key until no further movement is sensed. Mounting the rear mudguard and rear wheel: Required tools include 3/4mm allen keys, 10mm/15mm spanners/wrenches. First, mount the mudguard at the top metal bracket using the long M4mm and 10mm spanner, secondly attach the metal support struts using a 3mm allen key and screw them into the threaded holes found on the frame dropouts. Place the rear wheel in the dropouts and tighten the quick release axle, next, attach the XT di2 rear derailleur using a 5mm allen key, remembering to grease the threads on the bolt. Plug in the di2 cable and test the shifting function. Attaching the cockpit: The stem and handlebar need to be mounted onto the steerer rod using a 4mm allen key. Roughly align the front wheel so it is facing directly forward and slide the stem onto the steerer rod. Then, screw in the headset top cap using a 5mm allen key. Finally, tighten the two rear facing bolts on the stem to 5Nm ensure the front wheel is properly aligned and there is no lateral movement in the headsets.

When setting up your bike for your personal riding style, it is important to bear in mind safety and the ability to maintain full control of the bike under all circumstances. You may be an extremely experienced cyclist, but the Bullitt is a large bike and getting to grips with the extended front wheel takes some practise, so air on the side of caution when initially adjusting seatpost and stem height. You can always raise the saddle to get full leg extension later and when the time comes. Double check the minimum insertion markings on the seatpost and keep the saddle level for more efficient riding. Be sure to take your first ride in an environment free from traffic and where you can get accustomed to the steering, controls and general nuances of the bike. Double check local regulations on carrying children and always ensure they are strapped in. Important: Ensure quick release clamps on both the seatpost and the Easyup stem-lifter are properly tightened and that both wheels are secure. Test the brakes at low speed and your ability to reach the brake levers.